

STAR 10

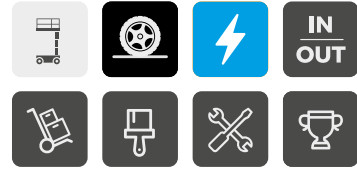

OPTIMAL AGILITY IN CONFINED WORKING AREAS

- > Progressive electric drive AC motors
- > Zero tail swing
- > 3 m outreach vertical jib

MINIMAL MAINTENANCE & DOWNTIME

- > Maintenance free brushless AC motors
- > Haulotte Activ'Screen (onboard diagnostic)
- > Haulotte Activ'Energy Management take care of your batteries
- > Almost 0 battery maintenance: automatic & centralized waterfilling system

LONGER LIFE TIME

- > Unbreakable hoods in composite material
- > Durability multiplied by 3 on pins, bushes, non-painted parts and fastening hardware

SMART TRANSPORTABILITY

- > Versatile and effective transport solutions with forklift tine pockets
- > 25 % gradeability to easily climb truck ramps



STAR 10

VERTICAL MASTS

TECHNICAL DATA

STAR 10

Working height	10 m
Platform height	8 m
Horizontal outreach	3 m
Lift capacity - inside	200 kg (2 pers.)
Lift capacity - outside	200 kg (1 pers.)
Platform size	0.78 x 0,98 m
A Length	2.7 m
B Width	1 m
C Height - stowed	1.99 m
Tailswing	0 cm
D Wheelbase	1.2 m
E Ground clearance	10 cm
Max driveable platf. height	8 m
Drive speed proportional	0.6 - 5 km/h
Turning radius - outside	1.88 m
Turntable rotation	345 °
Vertical jib rotation	130° (+ 70 ° / - 60 °)
Tilt alarm	3 °
Gradeability	25 %
Tyres - non marking	16 x 5 x 10.5
Hydraulic system capacity	7 l
Power source	24 V - 250 Ah
Weight	2 677 kg

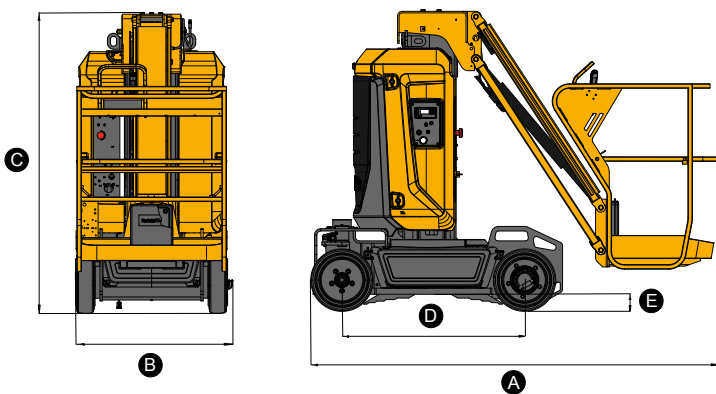

STANDARD EQUIPMENT

- > Haulotte Activ'Energy Management: Smart CAN charger
- > Automatic centralized battery filling
- > 24 V electric drive brushless AC motors
- > 24 V - 250 Ah traction batteries
- > Battery charge indicator
- > On-board diagnostic tool Haulotte Activ'Screen
- > Forklift tyne pockets
- > Towing hooks and lifting eyes
- > Passive potholes
- > Non-marking tyres
- > Brake release
- > Hourmeter
- > Horn
- > Emergency stop buttons at platform and ground level
- > Load controller in the platform
- > Emergency hand pump
- > 2 control stations at platform and ground level
- > 2 safety harness points in the platform
- > Drop bar entry
- > Travel alarm

OPTIONS AND ACCESSORIES

- > Haulotte Activ'Shield Bar (standard in AUS / NZ)
- > Power line in platform
- > Air line in platform
- > Swing door entry gate
- > Biodegradable oil
- > Maintenance-free batteries
- > Telematics ready
- > Hydraulic oil for cold countries
- > Flashing light (standard in AUS / NZ)
- > Working light

